



Applications

- Uninterruptible Power Supply (UPS)
- Electric Power System (EPS)
- Emergency Light
- Golf cart, Electric vehicle
- Railway signal system
- Marine and power stations
- Aircraft signal system
- Alarm and security system
- Electronic apparatus and equipment
- Electric powered bicycle & Wheelchair
- Communication power supply
- Solar powered systems

Battery Construction

COMPONENT	POSITIVE PLATE	NEGATIVE PLATE	CONTAINER	COVER	SAFETY VALVE	TERMINAL	SEPARATOR	ELECTROLYTE
Raw material	Lead dioxide	Lead	ABS	ABS	Rubber	Copper	Fiberglass	Colloidal silicon

Performance Characteristics

- **Nominal Voltage** 12V
- **Number of Cell** 6
- **Nominal Capacity (77°F /25°C)**
 - 100 Hour rate (1.66A, 11.1V) 166Ah
 - 20 Hour rate (7.5A,10.8V) 150Ah
 - 10 Hour rate (13.8A, 10.5V) 138Ah
 - 1 Hour rate (87A, 9.6V) 87Ah
- **Internal Resistance**
 - Fully charged battery (77°F /25°C) 7mΩ
- **Operating Temperature Range**
 - Discharge -20 ~ 65°C
 - Charge -10 ~ 65°C
 - Store -20 ~ 65°C
- **Self-Discharge 68°F (20°C)**
 - Capacity declined per month average 3%
- **Max. discharge current 77°F /25°C** 1000A(5S)
- **Charge Methods: constant voltage charge 77°F /25°C**
 - Cycle use 14.28 ~ 14.52V
 - Max. Current 37.5A
 - Standby use 13.38 ~ 13.68V

General Features

- **Micro millimeter SiO₂ and H₂SO₄ technology for efficient gas recombination of up to 99%.**
- **Maintenance free and no water adding required.**
- **Not restricted for air transportation as Nollon Battery complies with IATA/ICAO special provision A67.**
- **Raw material used in Nollon battery is of CE and UL (MH49077) standards.**
- **Computer designed lead-calcium tin plate grid alloy provides high power density and less gassing.**
- **ABS case (optional for Fire Retardant case).**
- **Low self-discharge and good recovery from deep discharge.**
- **Spill/leak proof and vibration resistant.**
- **Long service life for float or cyclic applications.**
- **Design life 10 years**

Dimensions and Weight

Type	Length	Width	Height	Total Height	Approx. Weight
SI Units	482mm	170mm	242mm	242mm	44Kg
English Units	19.0inch	6.69inch	9.53inch	9.53inch	96.8lbs

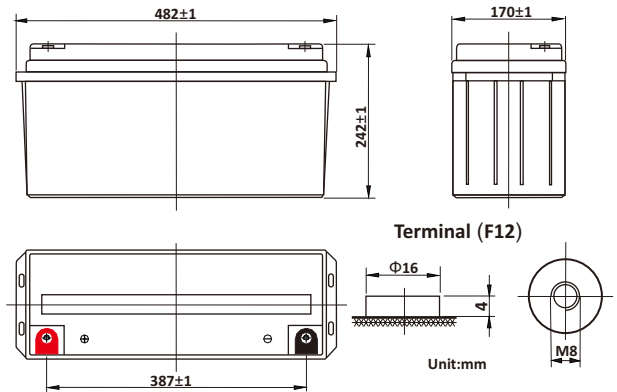

Constant Current Discharge (Amperes at 77°F/25°C)

V/cell	5min	10min	15min	30min	1h	3h	5h	10h	20h
1.60	381	308	252	146	87.0	36.9	25.0	14.3	7.60
1.65	352	296	239	143	85.1	36.5	24.7	14.2	7.56
1.70	330	278	228	138	83.0	36.0	24.5	14.0	7.52
1.75	318	261	216	132	81.3	35.0	24.3	13.8	7.50
1.80	286	250	205	126	79.2	33.7	23.8	13.3	7.46

Constant Power Discharge (Watts/cell at 77°F/25°C)

V/cell	5min	10min	15min	30min	45min	1h	2h	3h	5h
1.60	697	545	448	292	201	182	103	71.6	48.8
1.65	664	523	433	285	196	180	101	70.8	48.6
1.70	622	500	420	275	192	177	98.7	69.9	48.2
1.75	578	470	406	267	187	172	96.8	69.1	47.8
1.80	536	439	393	258	183	168	95.0	68.1	47.3

(Note: The above characteristics data are average values obtained within three charge/discharge cycles not the minimum values.)

