



NPL 2300 (2V 300AH)

Applications

- Telecommunication central station (wired or cellular)
- Power system communication, military communication, etc.
- Network communication including: data transmission, television signal transmission, etc.
- Uninterruptible Power Supply (UPS for Telecom)
- Emergency Power Supply (EPS)

Battery Construction

COMPONENT	POSITIVE PLATE	NEGATIVE PLATE	CONTAINER	COVER	SAFETY VALVE	TERMINAL	SEPARATOR	ELECTROLYTE
Raw material	Lead dioxide	Lead	ABS	ABS	Rubber	Copper/Plug	Fiberglass	Sulfuric acid

Performance Characteristics

- **Nominal Voltage** 2V
- **Number of Cell** 1
- **Nominal Capacity (77°F /25°C)**
 - 10 Hour rate (30A, 1.8V) 300Ah
 - 5 Hour rate (54A, 1.75V) 270Ah
 - 3 Hour rate (83A, 1.70V) 249Ah
 - 1 Hour rate (190A, 1.60V) 190Ah
- **Internal Resistance**
 - Fully charged battery (77°F /25°C) 1mΩ
- **Capacity affected by temperature (20 hour rate)**
 - 104°F (40°C) 102% 32°F (10°C) 85%
 - 77°F (25°C) 100% 5°F (-15°C) 65%
- **Self-Discharge 68°F (20°C)**
 - Capacity after 3 month storage 90%
 - Capacity after 6 month storage 80%
 - Capacity after 12 month storage 60%
- **Max. discharge current 77°F /25°C** 1500A(5S)
- **Charge Methods: constant voltage charge 77°F /25°C**
 - Cycle use 2.35 ~ 2.45V
 - Max. Current 60A
 - Standby use 2.25 ~ 2.30V

General Features

- **Oxygen recombination technology means the battery is maintenance free and no water adding required.**
- **Not restricted for air transportation as Nollon Battery complies with IATA/ICAO special provision A67.**
- **Raw material used in Nollon battery is of CE and UL (MH49077) standards.**
- **Computer designed lead-calcium tin plate grid alloy provides high power density and less gassing.**
- **ABS case (optional for Fire Retardant case).**
- **Sealed valve regulated thus allowing installation horizontally or vertically.**
- **Spill/leak proof and vibration resistant.**
- **Long service life for float or cyclic applications.**
- **Design life 15 years**

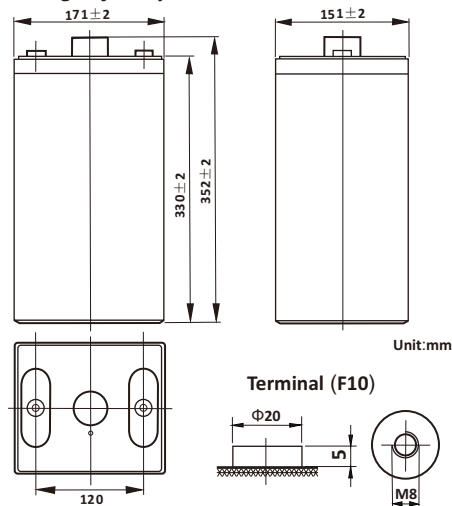

Dimensions and Weight

Type	Length	Width	Height	Total Height	Approx. Weight
SI Units	171mm	151mm	330mm	364mm	18.5Kg
English Units	6.73inch	5.94inch	13.0inch	14.3inch	40.8lbs

Constant Current Discharge (Amperes at 77°F/25°C)

V/cell	10min	15min	30min	45min	1h	3h	5h	10h
1.60	493	443	300	240	190	89.0	58.3	32.1
1.65	467	422	290	230	184	86.5	57.1	31.8
1.70	440	400	281	220	178	83.0	55.6	31.3
1.75	413	378	272	210	171	80.0	54.0	30.7
1.80	385	355	260	199	163	76.0	52.0	30.0

Constant Power Discharge (Watts/cell at 77°F/25°C)

V/cell	10min	15min	30min	45min	1h	2h	3h	5h
1.60	887	795	608	476	385	247	175	115
1.65	835	756	581	460	371	241	171	113
1.70	783	718	554	443	357	234	166	111
1.75	732	679	527	427	342	228	162	108
1.80	680	640	500	410	328	221	157	105

(Note: The above characteristics data are average values obtained within three charge/discharge cycles not the minimum values.)



