



Applications

- Uninterruptible Power Supply (UPS)
- Electric Power System (EPS)
- Emergency Light
- Emergency backup power supply
- Railway signal system
- Marine and power stations
- Aircraft signal system
- Alarm and security system
- Electronic apparatus and equipment
- DC power supply
- Communication power supply
- Network communication

Battery Construction

COMPONENT	POSITIVE PLATE	NEGATIVE PLATE	CONTAINER	COVER	SAFETY VALVE	TERMINAL	SEPARATOR	ELECTROLYTE
Raw material	Lead dioxide	Lead	ABS	ABS	Rubber	Copper/Plug	Fiberglass	Sulfuric acid

Performance Characteristics

- **Nominal Voltage** 12V
- **Number of Cell** 6
- **Nominal Capacity (77°F /25°C)**
 - 20 Hour rate (9.2A, 10.8V) 184Ah
 - 10 Hour rate (18A,10.8V) 180Ah
 - 5 Hour rate (32A, 10.5V) 160Ah
 - 1 Hour rate (115A, 9.6V) 115Ah
- **Internal Resistance**
 - Fully charged battery (77°F /25°C) 4mΩ
- **Capacity affected by temperature (20 hour rate)**
 - 104°F (40°C) 102% 32°F (10°C) 85%
 - 77°F (25°C) 100% 5°F (-15°C) 65%
- **Self-Discharge 68°F (20°C)**
 - Capacity after 3 month storage 90%
 - Capacity after 6 month storage 80%
 - Capacity after 12 month storage 60%
- **Max. discharge current 77°F /25°C** 950A(5S)
- **Charge Methods: constant voltage charge 77°F /25°C**
 - Cycle use 14.4 ~ 14.7V
 - Max. Current 45A
 - Standby use 13.6 ~ 13.8V

General Features

- **Oxygen recombination technology means the battery is maintenance free and no water adding required.**
- **Not restricted for air transportation as Nollon Battery complies with IATA/ICAO special provision A67.**
- **Raw material used in Nollon battery is of CE and UL (MH49077) standards.**
- **Computer designed lead-calcium tin plate grid alloy provides high power density and less gassing.**
- **ABS case (optional for Fire Retardant case).**
- **Sealed valve regulated thus allowing installation horizontally or vertically.**
- **Spill/leak proof and vibration resistant.**
- **Long service life for float or cyclic applications.**
- **Design life 10 years**

Dimensions and Weight

Type	Length	Width	Height	Total Height	Approx. Weight
SI Units	522mm	238mm	218mm	223mm	55.5Kg
English Units	20.55inch	9.37inch	8.58inch	8.78inch	122.3lbs

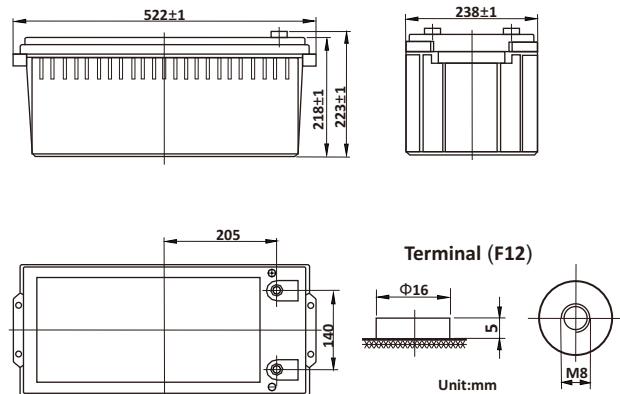

Constant Current Discharge (Amperes at 77°F/25°C)

V/cell	10min	15min	30min	1h	3h	5h	10h	20h
1.60	395	315	195	115	48.5	33.5	18.4	9.55
1.65	372	295	188	113	47.8	33.0	18.3	9.50
1.70	349	275	181	111	47.0	32.5	18.2	9.45
1.75	325	253	178	109	46.2	32.0	18.1	9.30
1.80	300	230	170	106	45.2	31.4	18.0	9.20

Constant Power Discharge (Watts/cell at 77°F/25°C)

V/cell	10min	15min	30min	45min	1h	2h	3h	5h
1.60	630	510	337	241	223	123	87.7	60.5
1.65	605	492	324	236	219	121	86.5	60.2
1.70	579	477	312	231	214	118	85.3	59.7
1.75	550	461	299	227	210	115	84.1	59.4
1.80	520	425	282	222	205	117	83.2	58.7

(Note: The above characteristics data are average values obtained within three charge/discharge cycles not the minimum values.)

